



NGF Optical Distribution Frame



- Introduction 4
- Things to Consider When Ordering..... 6
- Fiber Main Distributing Frame 10
- Front Facing Fiber Main Distributing Frame 11
- Fiber Slim Rack 12
- Preterminated Fiber Termination Blocks with Multifiber Cable-IFC 13
- Preterminated Fiber Termination Blocks with MPO Connectors 15
- Adapter-Only Fiber Termination Blocks..... 16
- Adapter-Only Fiber Termination Blocks-Conversion Kits..... 17
- Cable Clamping Kit and Block Conversion Kit..... 17
- Fiber Combination Blocks 18
- Fiber Combination Block Accessories 20
- Value-Added Module (VAM) MicroVAM Chassis 21
- Fiber Optic Terminal Jumper Storage Panel 22
- Fiber Optic Terminal Jumper Storage Panel
 - Zoning Recommendations 23
- Fiber Optic Terminal Jumper Storage Panel Ordering Information 24
- Equipment Frame 25
- Equipment Frame Splicing Solutions 26
- Splice Trays 26
- NGF to NG3® Frame Spacer Kit..... 27
- End Guard 28
- Work Shelf..... 28
- Frame Extender..... 29
- Grounding Kit..... 29
- AC Outlet Kit..... 29
- Frame Installation Kit..... 30
- Isolation Pad 30
- Cable Clamp Kit 31
- Sliding Adapter Pack..... 32
- Standard Cross-Connect Patch Cord Lengths 33
- Ordering Information for Patch Cords and Attenuators..... 33



NGF Optical Distribution Frame

Introduction

Frame

ADC's next generation frame (NGF) product line has fiber frames designed to fit a variety of network applications. Each frame option is designed with an emphasis on superior cable management and ease of use, including features such as ample trough space for cable and jumpers, easy access to connectors and storage for jumpers. The frame sections are shipped from the factory fully equipped with all cable management hardware including integrated jumper slack storage.

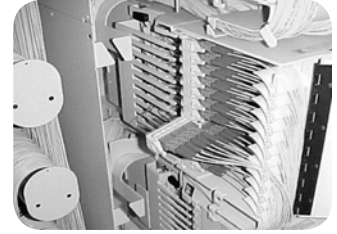

Fiber Termination Block (FTB)

ADC's FTB is available with industry-standard adapters in block configurations of 72-, 96- and 144-positions. Also, a 192-position FTB is available using LC adapters. FTBs utilize sliding adapter packs to gain easy access to both the front and rear terminations. To accommodate varying network requirements and speed installation, FTBs can be ordered with adapters only or preterminated with either intrafacility cable (IFC) or outside plant (OSP) cables.

Fiber Combination Block (FCB)

Our FCB provides termination and on-frame splicing capabilities. This configuration occupies two mounting positions on the frame section. They are available with industry-standard adapters in block configurations of 72-, 96- and 144-positions. An FCB with 192-positions is also available using LC adapters.

Value-Added Module Block (VAM)

Adding signal management and enhancement functions, such as splitters, couplers and wavelength division multiplexers, optimizes the value of your fiber network, by providing nonintrusive access to the optical signal for monitoring and testing signal integrity. There is a block configuration available to accommodate Micro Value-Added Modules (MicroVAMs) for applications requiring splitters or WDMs.

Fiber Optic Terminal Storage Panel

ADC's fiber optic terminal storage panel is used as a storage apparatus for up to 16 feet of equipment (FOT) jumpers at the fiber frame lineup. This panel can be installed between fiber frames and at the end of a lineup.



NGF Optical Distribution Frame

Introduction

Product Overview

Recommended applications	Medium to large fiber count applications or any space constrained applications. Highest fiber count solution available.
Description	High-density solution using 72-, 96-, 144- and 192-position blocks (FTB)
Number of fibers, future growth potential	Up to 29,177 in 17 frames using 144-position blocks, SC connectors and 1.7 mm patch cords Up to 32,939 in 15 frames using 192-position blocks, LC connectors and 1.7 mm patch cords
Interconnect	Good
Cross-connect	Excellent
Accommodates on-frame splicing	Good
Accommodates off-frame splicing	Excellent
Density – terminations per frame	1,728 terminations using standard connectors; 2,304 terminations using LC connectors
Front access to rear connector	Yes
VAM capabilities	Yes. Separate panel required
Slack storage location	On-frame (integrated jumper slack storage)
Connector access	Sliding adapter pack



NGF Optical Distribution Frame

Things to Consider When Ordering

Frame Capacity Requirements (Important Facts on Trough Space)

	144 FTB (1,728/frame)	96 FTB (1,152/frame)	72 FTB (864/frame)
NGF	12 frames	18 frames	24 frames
Front Facing NGF	4 frames	6 frames	8 frames

Calculation assumptions:

- Per Telecordia® GR-449-CORE, Issue 2 requirements
- 2.0 mm jumpers (maximum recommended diameter for all NGF products)
- 2" maximum jumper pile
- 50% of jumpers do not appear at any given place in lineup (50% rule)

Frame Lineup Capacity Comparisons

2.0 mm Jumpers/Maximum Recommended Diameter for NGF Products			
	NGF Frame: 1,728 Fiber Terminations	Conventional Frame: 1,152 Fiber Terminations	Conventional Frame: 648 Fiber Terminations
Horizontal trough space	30"	10" (5" Upper and Lower)	5" Lower
Maximum number of terminations allowed in a frame lineup before exceeding 2" pileup	21,081	8,240	4,120

NGF Frame Considerations

	NGF Frame	Front Facing NGF Frame	Slim Rack
Flexibility/ability to grow frame lineup	Yes	Yes	No
Interconnect	Supports	Supports	Supports
Cross-connect	Supports	Supports	Supports
On-frame splicing	Supports	Supports	Supports
Off-frame splicing	Supports	Supports	Supports
Rear access required	Yes	No	No
All front access	No	Yes	Yes
Footprint	30" Wide x 24" Deep	30" Wide x 19" Deep	19" Wide x 19" Deep
Horizontal trough space available	30"	9"	N/A

Block and Frame Termination Capacity

NGF Block Termination Capacity	NGF Frame Termination Capacity
72	864
96	1,152
144	1,728
192 (LC connectors only)	2,304



NGF Optical Distribution Frame

Things to Consider When Ordering

Zoning Recommendations (by Vertical)

5/07 • 103742AE Optical Distribution Frames

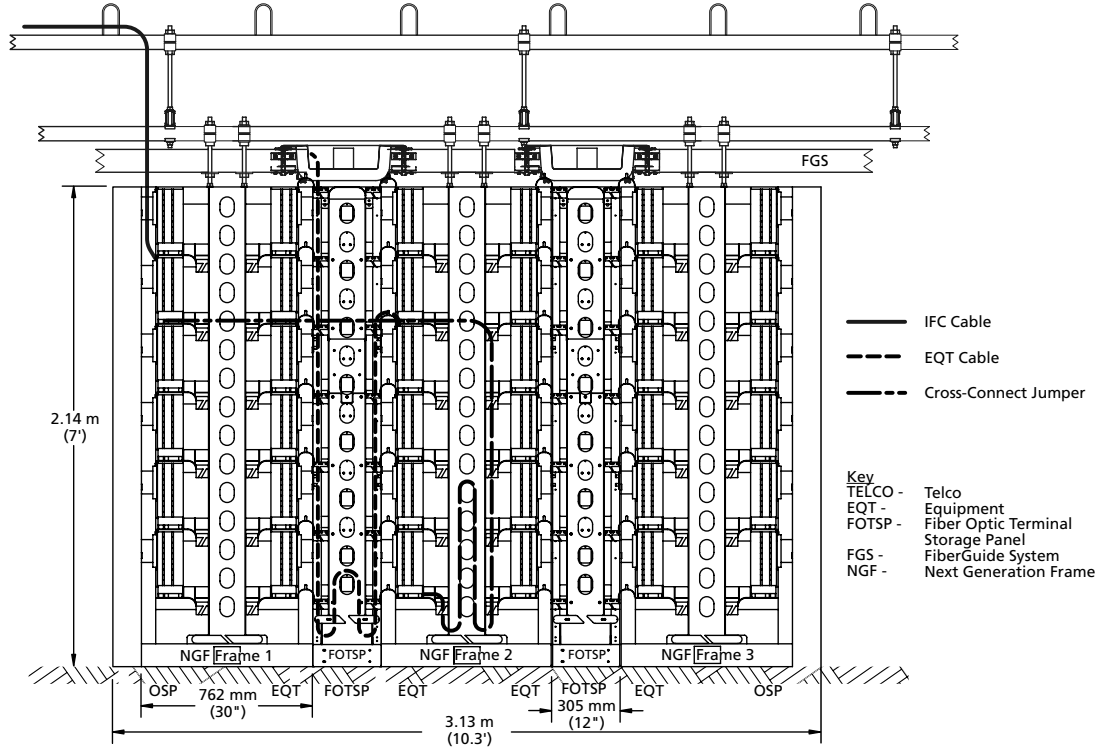

Cross-Connect Application using 12-inch wide FOTSP in a 2:1 Application
(2 Equipment to 1 OSP)

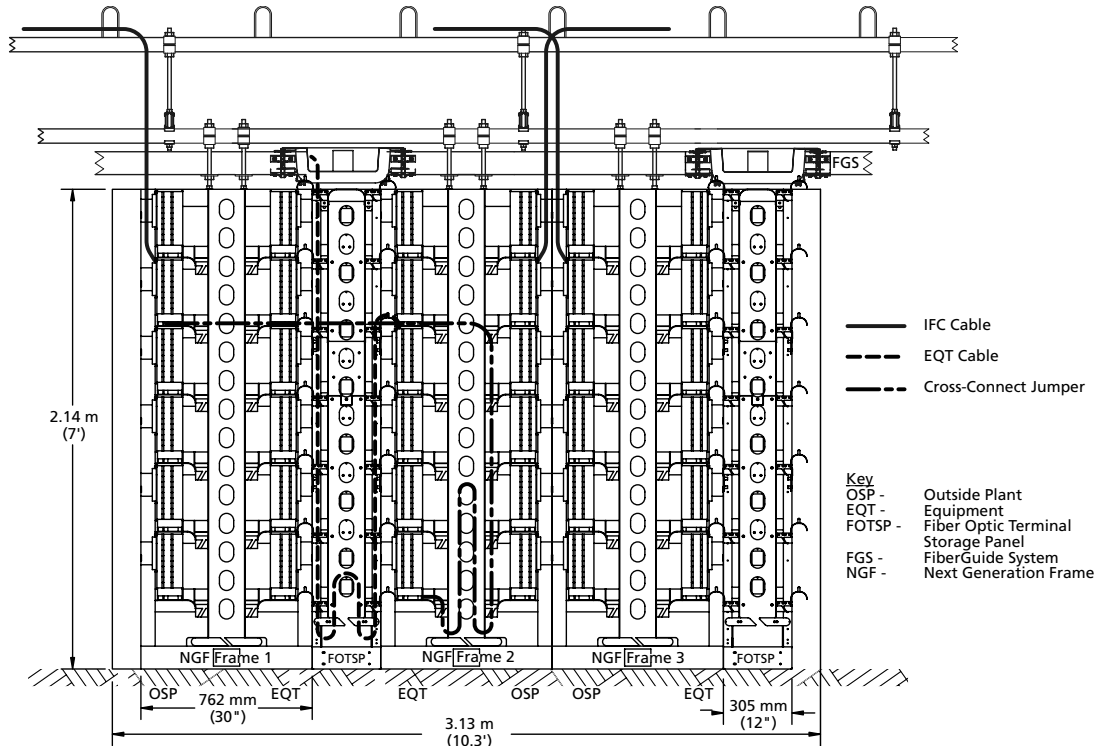

Cross-Connect Application using 12-inch wide FOTSP in a 1:1 Application
(1 Equipment to 1 OSP)

High-Density Frame Solutions



NGF Optical Distribution Frame

Things to Consider When Ordering

Zoning Recommendations (by Frame)

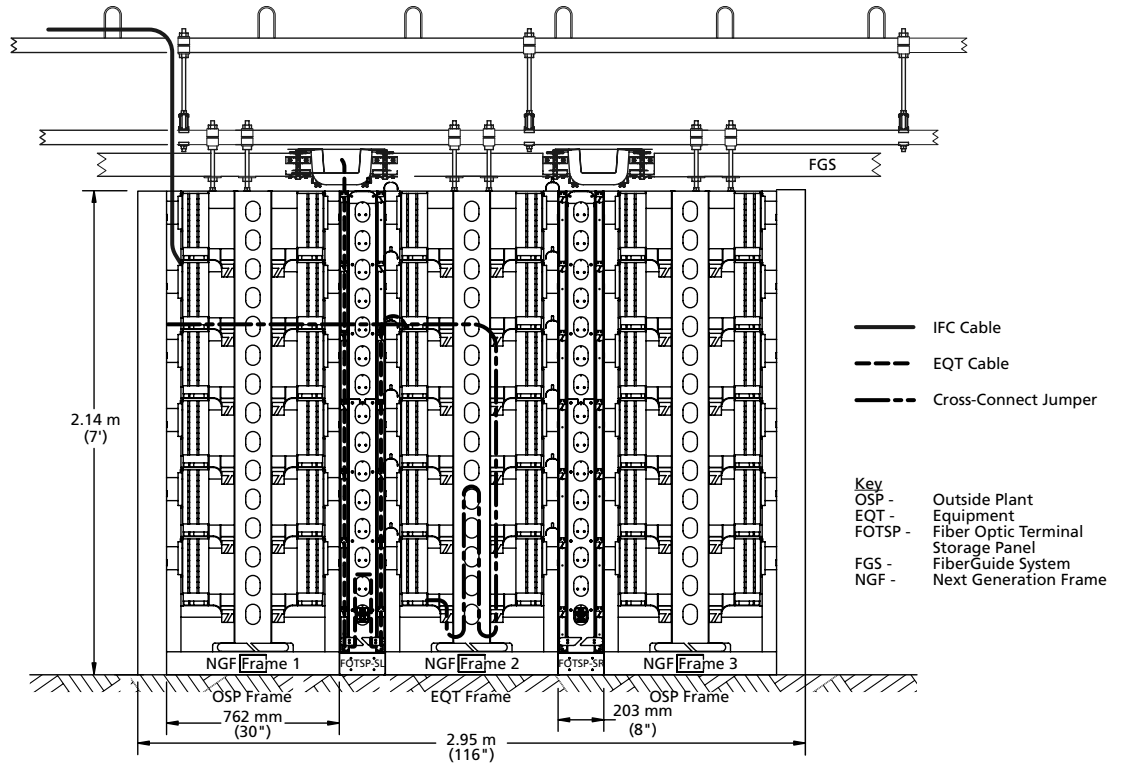

Cross-Connect Application using 8-inch wide FOTSP in a 2:1 Application
(2 Equipment to 1 OSP)

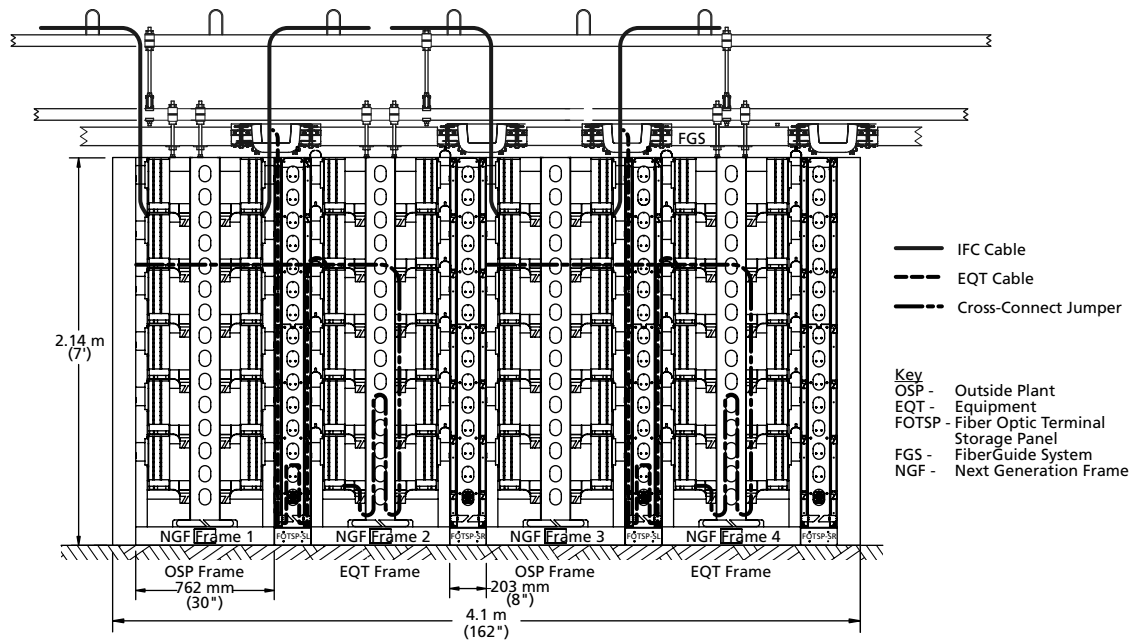

Cross-Connect Application using 8-inch wide FOTSP in a 1:1 Application
(1 Equipment to 1 OSP)

High-Density Frame Solutions

Optical Distribution Frames

5 / 0 7 • 1 0 3 7 4 2 A E



NGF Optical Distribution Frame

Things to Consider When Ordering

How to Order

Main Components of the NGF

Catalog Number Quantity

1) Select the desired Frame based on application

- Fiber Main Distributing Frame - Page 10

- Front Facing Fiber Main Distributing Frame - Page 11

- Fiber Slim Rack - Page 12

- Equipment Frame - Page 25

2) Select the desired Fiber Termination Blocks

- Preterminated Fiber Termination Blocks with
Multifiber Cable-IFC - Pages 13-14

- Preterminated Fiber Termination Blocks with
MPO Connectors - Page 15

- Adapter-Only Fiber Termination Blocks - Page 16

- Adapter-Only Fiber Termination Blocks-Conversion Kits - Page 17

- Fiber Combination Blocks - Pages 18-19

- Splice Tray - Pages 20, 26

- Splice Protector Sleeve - Page 20

3) Fiber Optic Terminal Jumper Storage Panel - Pages 22-24

- 12" W (universal) - Page 24

- Front Facing 12" W (universal) - Page 24

- 8" W (left or right orientation) - Page 24

- Front Facing 8" W (left or right orientation) - Page 24

Optional Equipment

4) Value-Added Module (VAM) Chassis - Page 21

5) NGF to NG3 Frame Spacer Kit - Page 27

6) End Guard

- End Guard (universal) - Page 28

- Front Facing End Guard (universal) - Page 28

7) Work Shelf - Page 28

8) Frame Extender - Page 29

9) Grounding Kit - Page 29

10) AC Outlet Kit - Page 29

11) Frame Installation Kit - Page 30

12) Isolation Pad - Page 30

13) Cable Clamp Kit - Page 31

14) Sliding Adapter Pack - Page 32

15) Patch Cord - Pages 122-126*

16) In-Line Attenuator - Page 127

*See page 33 for standard cross-connect patch cord lengths.

Optical Distribution Frames

5 / 0 7 • 1 0 3 7 4 2 A E

High-Density Frame Solutions



NGF Optical Distribution Frame

Fiber Main Distributing Frame

The zone 4 rated fiber main distributing frame (FMDF) is the cornerstone of the NGF product line. The footprint of the frame is GR-449-CORE, Issue 2 compliant. This innovative frame has six 5-inch horizontal troughs for a total of 30 inches of horizontal trough space. This abundant trough space minimizes fiber pile up and congestion leading to easier jumper traceability and removal. The frame has 12 fiber termination block (FTB) mounting positions equally divided between vertical columns on the left and right sides of the frame as shown in the figure below. The frame provides sufficient vertical trough space for the highest termination density applications and includes built-in jumper storage that will store up to 3.5 meters of jumper slack. The NGF is designed such that only a single jumper length (6 meters) is required to go between any two termination points within a frame.

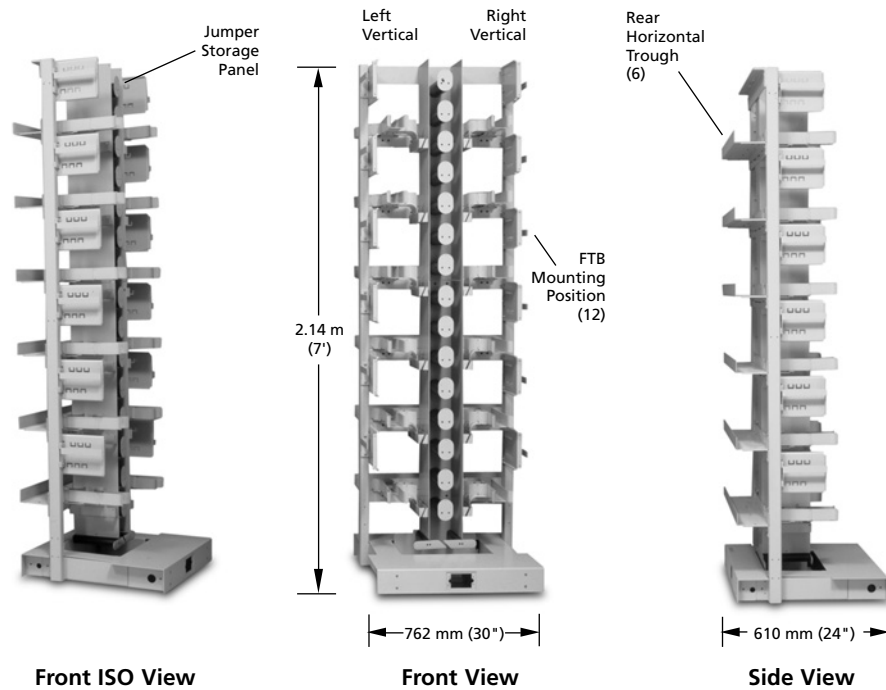

Ordering Information

Description	Dimensions (HxWxD)	Maximum Termination Capacity	Catalog Number
NGF fiber main distributing frame	2.14 m x 762 mm x 610 mm (7' x 30" x 24")	1,728 (2,304 using LC connectors)	NGF-MDF7A100-30

Each frame section includes heavy duty floor anchor bolts for concrete floor applications. See page 30 for additional mounting options.



NGF Optical Distribution Frame

Front Facing Fiber Main Distributing Frame

The zone 4 rated front facing fiber main distributing frame (F3MDF) is designed for single-sided access applications and may be mounted up against a wall or back-to-back to save floor space. Unlike the F MDF, the more compact F3MDF is equipped with a single 9-inch horizontal trough on the front. The F3MDF has 12 fiber termination block (FTB) mounting positions equally divided between vertical columns on the left and right sides of the frame as shown below. The frame provides sufficient vertical trough space for the highest termination density applications and includes built-in jumper storage that will store up to 3.5 meters of jumper slack.

Optical Distribution Frames

5/07 • 103742AE

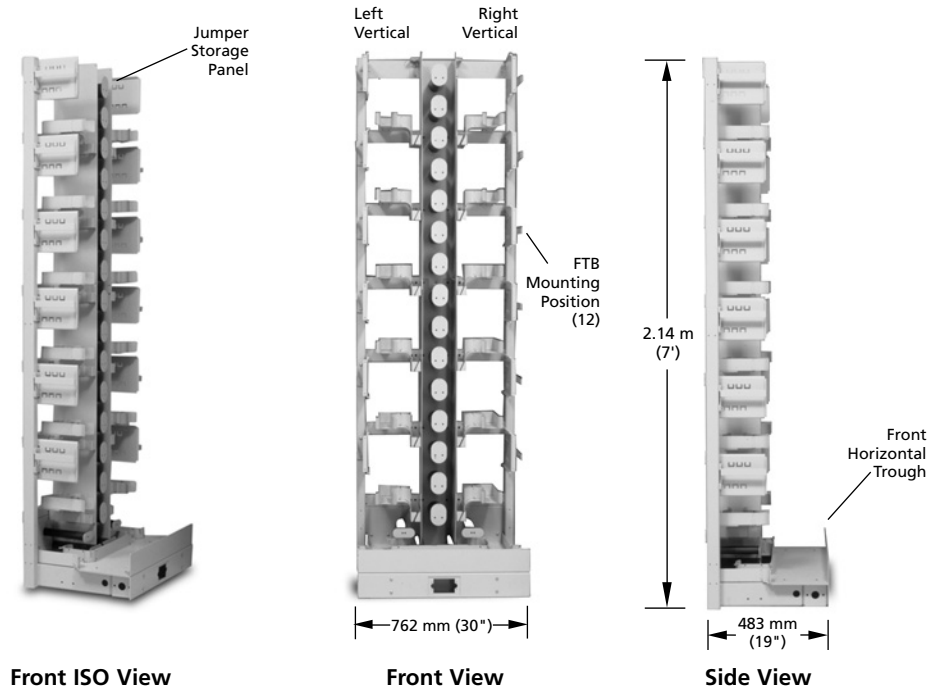

Ordering Information

Description	Dimensions (HxWxD)	Maximum Termination Capacity	Catalog Number
NGF front facing fiber main distributing frame	2.14 m x 762 mm x 483 mm (7' x 30" x 19")	1,728 (2,304 using LC connectors)	NGF-F3MDF7A100-30

Each frame section includes heavy duty floor anchor bolts for concrete floor applications. See page 30 for additional mounting options.

High-Density Frame Solutions



NGF Optical Distribution Frame

Fiber Slim Rack

The fiber slim rack is designed for lower density applications than the FMDF or F3MDF. It has six fiber termination block (FTB) mounting positions and is designed for single-sided access applications. The slim rack is intended for use in a single frame application and should not be used in a multi-frame lineup. The built-in jumper storage panel will store up to 3.5 meters of jumper slack.

When ordering FTBs for the slim rack, note that only LEFT oriented blocks are used on this frame.

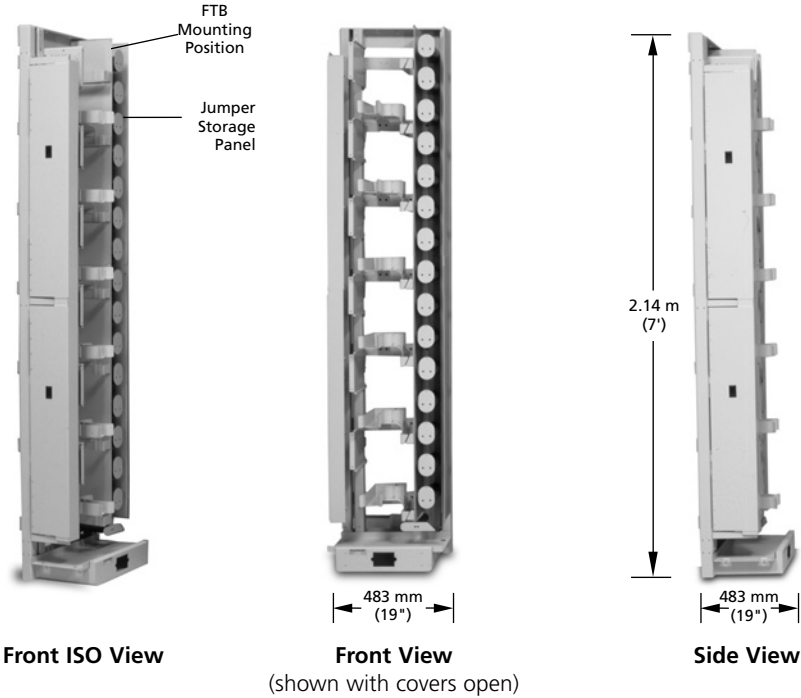

Front ISO View

Front View
(shown with covers open)

Side View

Ordering Information

Description	Dimensions (HxWxD)	Maximum Termination Capacity	Catalog Number
NGF fiber slim rack	2.14 m x 483 mm x 483 mm (7' x 19" x 19")	864 (1,152 using LC connectors)	NGF-SLM7A100

Each frame section includes heavy duty anchor bolts for concrete floor applications. Not rated for zone 4 applications. See page 30 for additional mounting options.



NGF Optical Distribution Frame

Preterminated Fiber Termination Blocks with Multifiber Cable – IFC

Preterminated fiber termination blocks (FTBs) are available with either indoor or outdoor rated cable in ribbon or stranded configurations. All blocks are 100% factory tested to guarantee continuity and reliable connections. Preterminated FTBs make installation quick and easy, reducing labor costs. Before ordering, determine the block orientation and cable exit direction. Preterminated FTBs may be ordered with a "left" orientation (mounts on the left side of the frame) or a "right" orientation (mounts on the right side of the frame). The cable exit direction will be either "upward" (cables terminated to the rear side of the block exit up toward the top of the frame) or "downward" (cables terminated to the rear side of the block exit down toward the bottom of the frame).

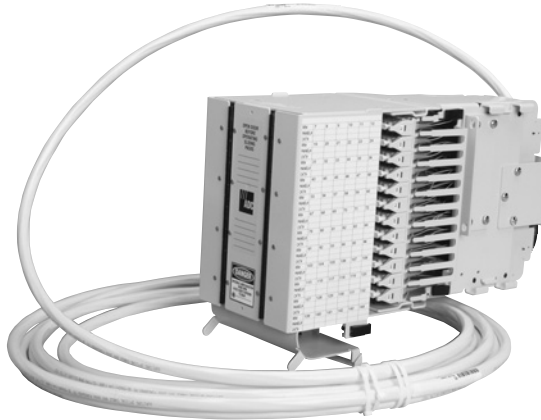

Preterminated FTB with IFC

5 / 0 7 • 1 0 3 7 4 2 A E Optical Distribution Frames

High-Density Frame Solutions

Definition of Variables	
1	Block Type General adapter type required in the FTB
2	Block Capacity Maximum number of terminations that the FTB will accommodate when fully loaded
3	Block Orientation Vertical column of the frame the FTB is to be mounted on
4	Cable Exit Direction Direction the equipment jumpers or OSP cable will exit from the FTB
5	Connector and Adapter Type #1 Specific adapter/connector type required at the FTB
6	Connector Type #2 Specific connector type required at the far end opposite the FTB
7	Cable Type Type of cable to be terminated to the FTB
8	Cable Length Required length of the cable terminated to the FTB

Ordering information follows on next page.



NGF Optical Distribution Frame

Preterminated Fiber Termination Blocks with Multifiber Cable-IFC

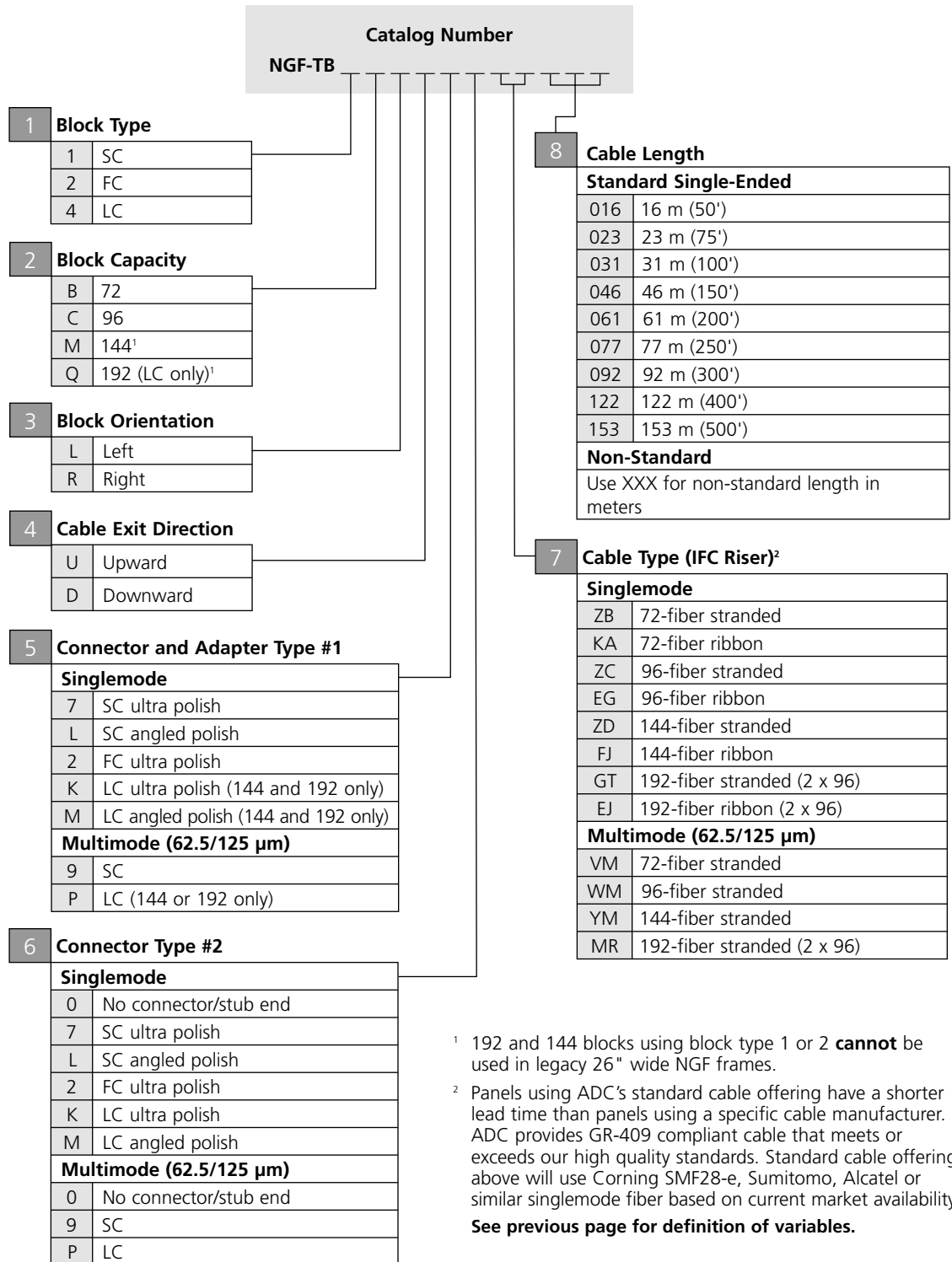

¹ 192 and 144 blocks using block type 1 or 2 **cannot** be used in legacy 26" wide NGF frames.

² Panels using ADC's standard cable offering have a shorter lead time than panels using a specific cable manufacturer. ADC provides GR-409 compliant cable that meets or exceeds our high quality standards. Standard cable offering above will use Corning SMF28-e, Sumitomo, Alcatel or similar singlemode fiber based on current market availability. **See previous page for definition of variables.**

Other configurations are available upon request. Please contact ADC Technical Assistance Center.



NGF Optical Distribution Frame

Preterminated Fiber Termination Blocks with MPO Connectors

Fiber termination blocks (FTBs) with MPO connectors provide MPO connectability on the rear of the block for easy connection of MPO fiber cables. The termination portion of the fiber block utilizes sliding adapter packs to gain easy access to standard connectors and adapters on the front of the block and provides a location for standard patch cord connections. The block is internally cabled at the factory for easy installation and occupies one position of the frame. Before ordering, determine the block orientation needed as the blocks may be ordered with a "left" orientation (mounts on the left side of the frame) or a "right" orientation (mounts on the right side of the frame).



Preterminated FTB with MPO Connectors

5 / 0 7 • 1 0 3 7 4 2 A E Optical Distribution Frames

Definition of Variables	
1	Block Capacity Maximum number of terminations that the FTB will accommodate when fully loaded
2	Block Orientation Vertical column of the frame the FTB is to be mounted on
3	Front Connector and Adapter Type Specific adapter/connector type required at the FTB
4	Pigtail Type Type of pigtail used within the FTB
5	Number of Pigtail Assemblies Number of pigtails to be pre-installed in the FTB

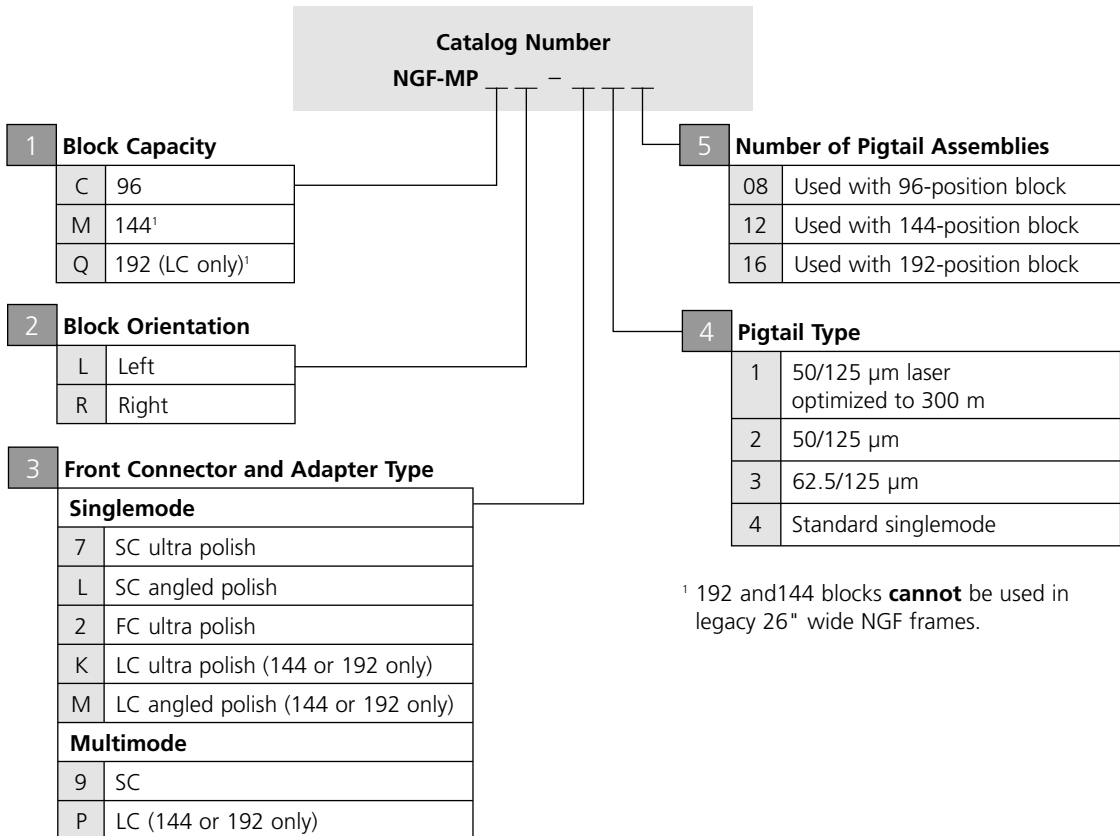

Other configurations are available upon request. Please contact ADC Technical Assistance Center.

High-Density Frame Solutions



NGF Optical Distribution Frame

Adapter-Only Fiber Termination Blocks

Fiber termination blocks (FTBs) without fiber can be ordered fully loaded with adapters. Before ordering, determine the block orientation and cable exit direction. Adapter-only FTBs may be ordered with a "left" orientation (mounts on the left side of the frame) or a "right" orientation (mounts on the right side of the frame). The cable exit direction will be either "upward"* (cables terminated to the rear side of the block exit up toward the top of the frame) or "downward" (cables terminated to the rear side of the block exit down toward the bottom of the frame). All blocks with adapters only are configured to terminate single or dual jumpers on the rear of the block. If a multifiber breakout style cable (i.e., OSP/IFC) is to be terminated to the rear of the block, a separate clamping kit and replacement rear storage area kit is required (see page 17).

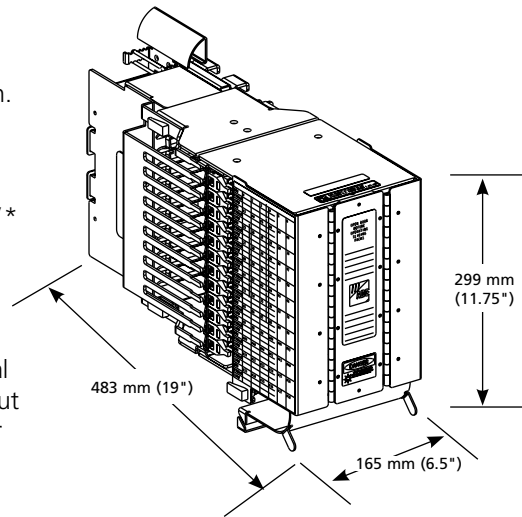

144-Position Right Upward FTB

* When using the fiber optic terminal jumper storage panels from page 24, a cable exit UP block must be used.

Definition of Variables	
1	Block Type General adapter type required in the FTB
2	Block Capacity Maximum number of terminations that the FTB will accommodate when fully loaded
3	Block Orientation Vertical column of the frame the FTB is to be mounted on
4	Cable Exit Direction Direction the equipment jumpers or OSP cable will exit from the FTB
5	Adapter Type Specific adapter type required in the FTB

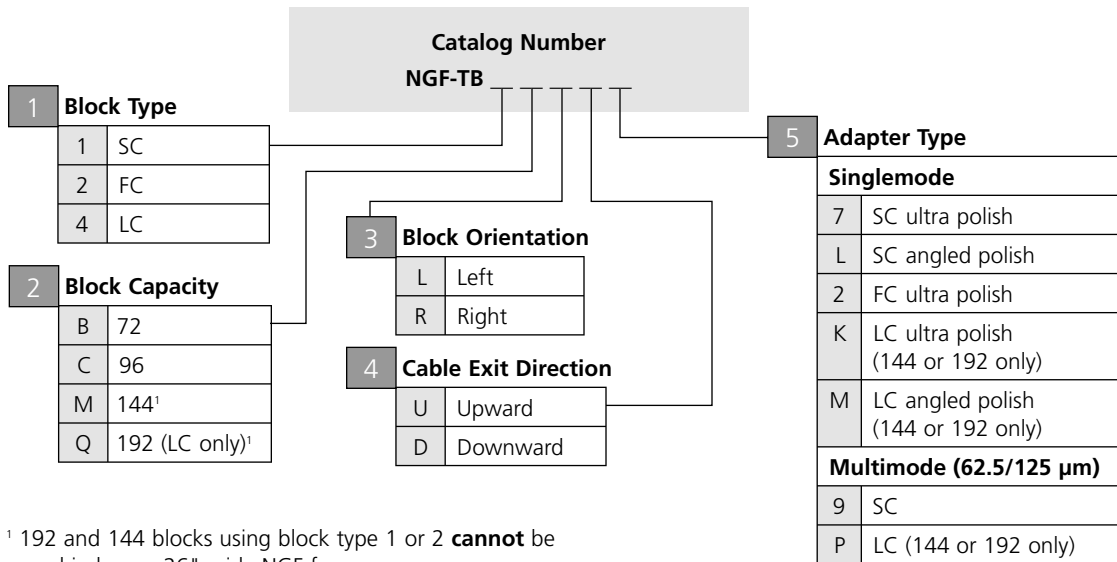

¹ 192 and 144 blocks using block type 1 or 2 **cannot** be used in legacy 26" wide NGF frames.

Other configurations are available upon request. Please contact ADC Technical Assistance Center.



NGF Optical Distribution Frame

Adapter-Only Fiber Termination Blocks – Conversion Kits

Cable Clamping Kit and Block Conversion Kit

Adapter-only blocks ordered from page 16 are configured to accommodate single fiber jumpers or multifiber breakout cables. Additional hardware is required if loading a preterminated intrafacility cable (IFC) or OSP cable. Block conversion kits are available to convert adapter-only blocks to blocks that will accept preterminated IFC or OSP style cables. The conversion kits contain the cable management hardware, brackets and cable clamps required to convert the block. The kit required will depend on the block style originally purchased.

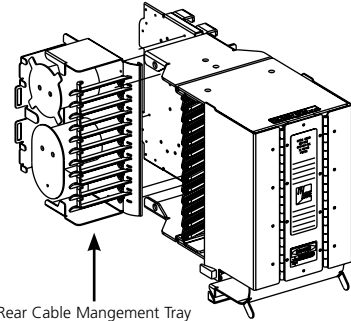

Rear Cable Management Tray for 144 Block Conversion Kits

144-Position Right FTB
(Shown with IFC Conversion Kit Loaded)

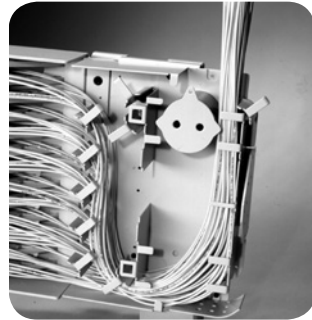

72-Position FTB Loaded with Jumpers

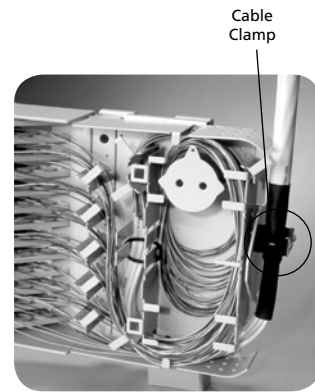

72-Position FTB Loaded with Multifiber Breakout Cable

Ordering Information

Description	Catalog Number
Block type originally purchased	
72-position blocks	NGF-ACCOSPKIT02
96-position blocks with rear cable management (Ordered before June 2002)	NGF-ACCOSPKIT01
96- or 144-position Left Up blocks	NGF-ACCRCMSLU
96- or 144-position Right Up blocks	NGF-ACCRCMSRU
96- or 144-position Left Down blocks	NGF-ACCRCMSLD
96- or 144-position Right Down blocks	NGF-ACCRCMSRD



NGF Optical Distribution Frame

Fiber Combination Blocks

Fiber combination blocks (FCB) provide the option to splice IFC/OSP cables on the frame with factory-installed fiber pigtails. The blocks are available with several different adapter types in block configurations of 72-, 96- or 144-positions. Also, a 192-position FCB is available using LC adapters. The termination portion of the fiber combination block utilizes sliding adapter packs to gain easy access to connectors on both the front and rear side of the block. The block is available with factory-installed pigtails for easy installation. Splice trays are shipped with the block if ordered with pigtails; otherwise trays must be ordered separately. The block is shipped with a cable clamp for OSP/IFC. The FCB occupies two mounting positions on a frame section. Before ordering, determine the block orientation. FCBs may be ordered with a "left" orientation (mounts on the left side of the frame) or a "right" orientation (mounts on the right side of the frame).

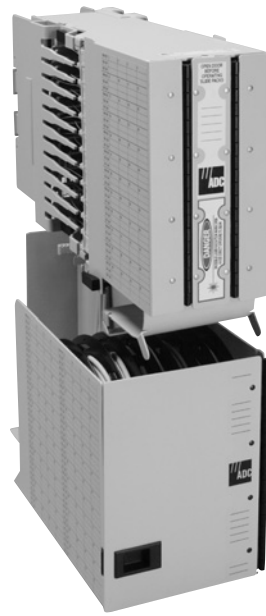

Fiber Termination/Splice Block

Ordering information follows on next page.



NGF Optical Distribution Frame

Fiber Combination Blocks

5/07 • 103742AE Optical Distribution Frames

Definition of Variables	
1	Block Type General adapter type required in the FCB
2	Block Capacity Maximum number of terminations that the FCB will accommodate when fully loaded
3	Block Orientation Vertical column of the frame the FCB is to be mounted on
4	Connector and Adapter Type Specific adapter/connector type required in the FCB
5	Pigtail Type Type of pigtail required
6	Number of Pigtail Assemblies Number of pigtails to be pre-installed in the FCB
7	Splice Chip Type of splice chip required for splice trays

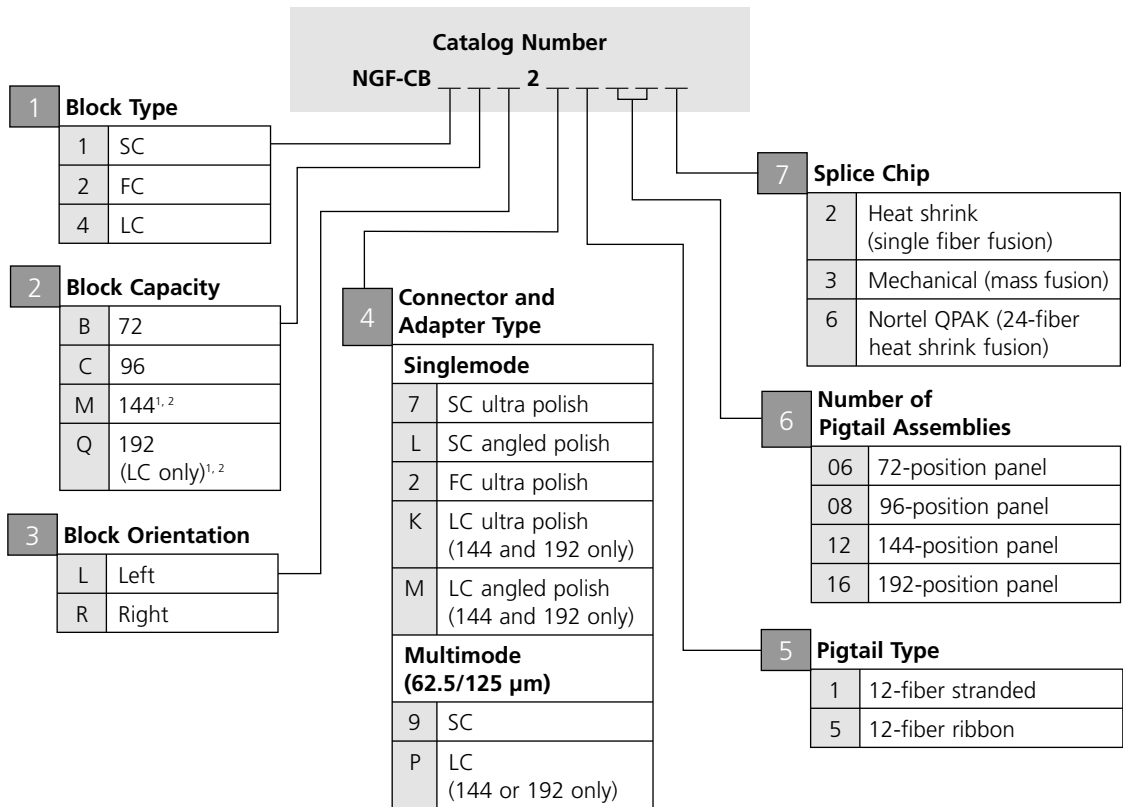

To order additional splice trays please see page 20.

¹ 192 and 144 blocks using block style 1 or 2 **cannot** be used in legacy 26" wide NGF frames.

² Must use Nortel QPAK splice chip in 144 and 192 blocks when splicing 24 single fibers.

Other configurations are available upon request. Please contact ADC Technical Assistance Center.

High-Density Frame Solutions



NGF Optical Distribution Frame

Fiber Combination Block Accessories

Splice Tray

For use when splice trays are not included with block at time of order.

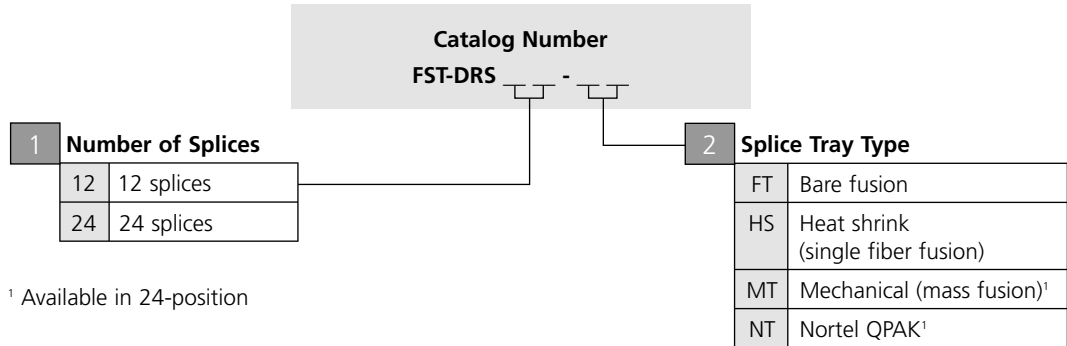

Splice Protector Sleeve

The splice protector sleeve is constructed to protect a splice post fusion. It is made from heat shrinkable material and contains a built-in strength member for physical protection of the fusion splice. The splice protection sleeve is placed on the fiber before making a splice, moved over the splice when the splice fusion is complete and shrunk into place. They are available in either single fiber or mass fusion sleeves.

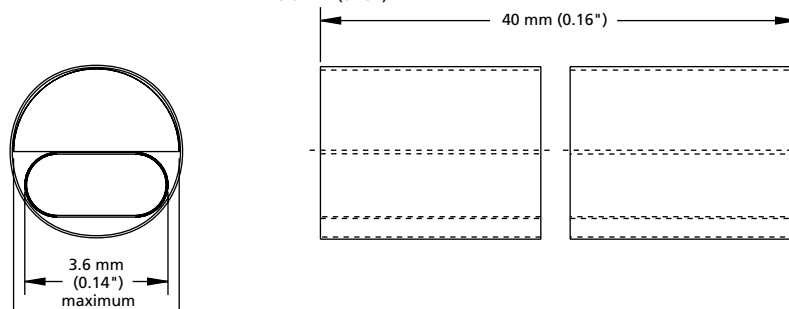
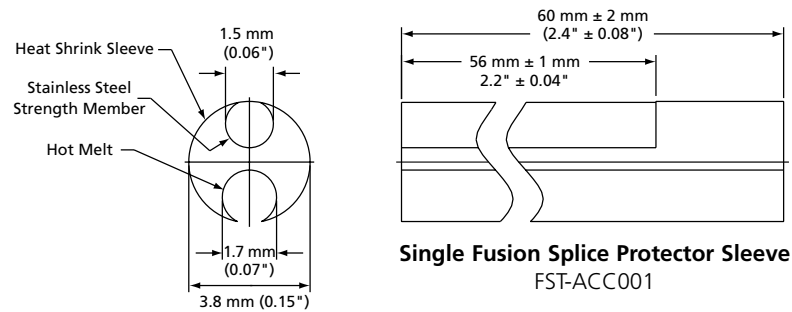

Ordering Information

Description	Catalog Number
Splice protector sleeve for;	
Single fiber – single fusion; 60 mm (2.4") length, 1 each	FST-ACC001
Single fiber – single fusion; 40 mm (1.6") length, 1 each	FST-ACC005
12-fiber ribbon – mass fusion – heat shrink; 40 mm (1.6") length, 1 each	FST-ACC006

Other configurations are available upon request. Please contact ADC Technical Assistance Center.



NGF Optical Distribution Frame

Value-Added Module (VAM) MicroVAM Chassis

The new NGF MicroVAM chassis is designed to mount on all standard NGF frames and is interchangeable with termination, splice, and storage modules. Each chassis accommodates up to 12 MicroVAM modules. The NGF MicroVAM chassis accommodates MicroVAM modules only.

For information on ADC legacy MiniVAM chassis and modules, please contact ADC Technical Assistance Center.



MicroVAM Chassis - Left Orientation
(Shown Loaded)

Ordering Information

Description	Dimensions (HxWxD)	Catalog Number
NGF MicroVAM chassis, unloaded - left orientation; accommodates 12 MicroVAM modules	300 mm x 455 mm x 132 mm (11.8" x 17.9" x 5.2")	NGF-VSPM-7000L
NGF MicroVAM chassis, unloaded - right orientation; accommodates 12 MicroVAM modules	300 mm x 455 mm x 132 mm (11.8" x 17.9" x 5.2")	NGF-VSPM-7000R

Value-Added Module (VAM) System

ADC offers an expansive line of monitor, splitter, WDM and CWDM VAM plug-in modules designed to meet all application needs. Please reference the **Value-Added Module (VAM) System Catalog #101663AE** for details at www.adc.com or contact ADC Customer Service.

Outside Plant Splitter System

For outside plant splitter solutions, please reference **OmniReach™ FTTX Solutions - Passive Optical Splitter Modules Catalog #102902AE** at www.adc.com or contact ADC Customer Service.



NGF Optical Distribution Frame

Frame Accessories

Fiber Optic Terminal Jumper Storage Panel

The fiber optic terminal jumper storage panel is an optional filler panel that provides up to 5 meters (16.4 feet) of slack storage for jumpers that run between terminal equipment and the rear ports of an NGF terminal block in cross-connect applications. This slack storage capability allows for greater flexibility in determining jumper lengths and allows for use of more standard length jumpers. This panel is installed within the NGF frame lineup between NGF frames. The fiber optic terminal storage panels are available in two different configurations depending on the way the NGF frame system is zoned. NGF frames can be zoned by vertical or by frame. A 12-inch wide panel is available that serves two verticals (one on each side) for use when frames are zoned by vertical. Also, 8-inch wide versions are available that serve a single vertical (left or right) for use when frames are zoned by frame.

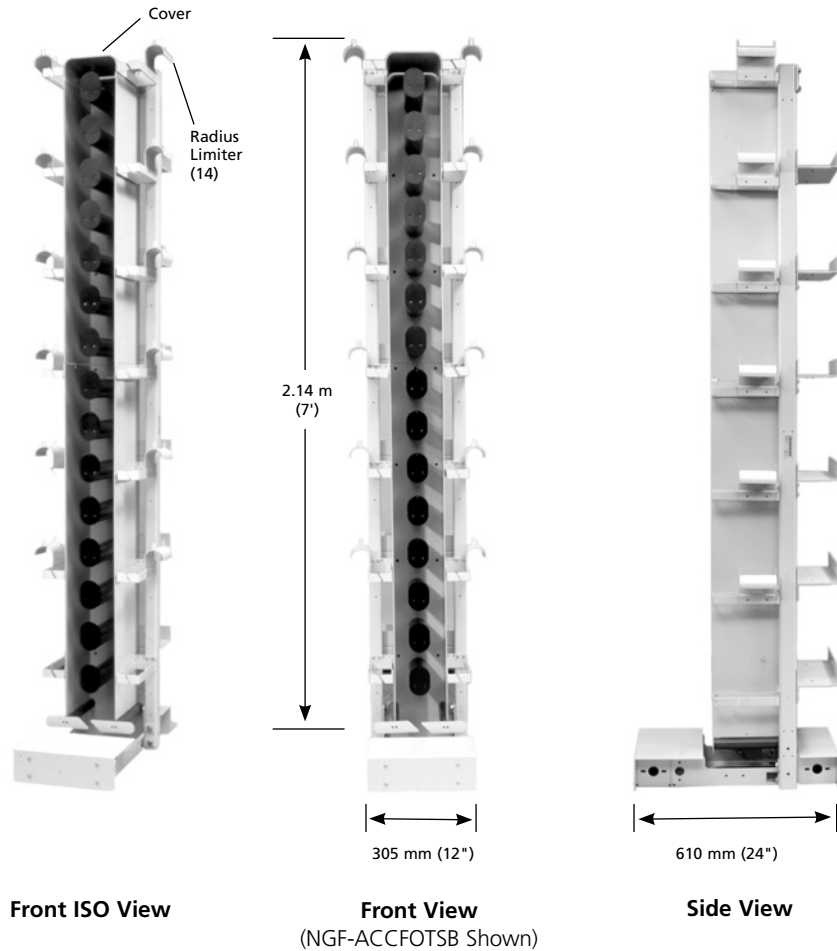

Ordering information follows on page 24.



NGF Optical Distribution Frame

Frame Accessories

Fiber Optic Terminal Jumper Storage Panel Zoning Recommendations

5/07 • 103742AE Optical Distribution Frames

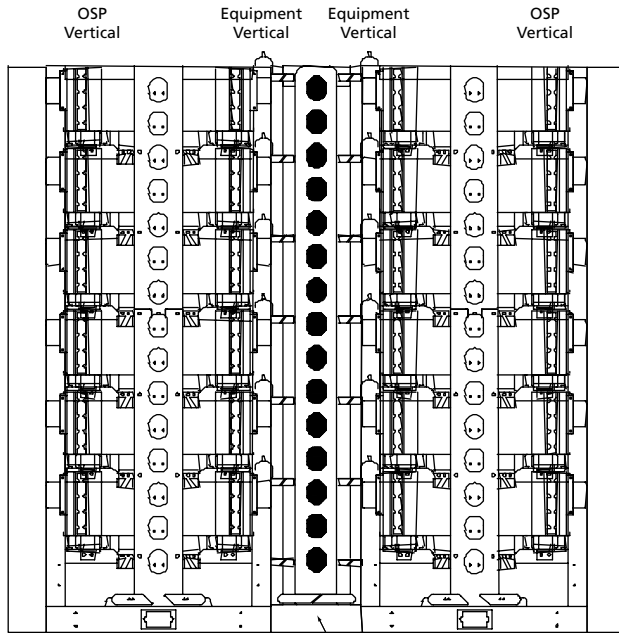

Zoned by Vertical

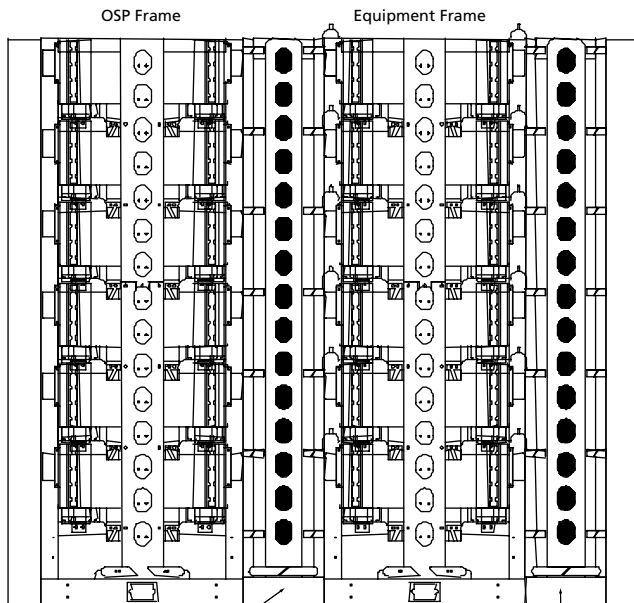

Zoned by Frame

High-Density Frame Solutions



NGF Optical Distribution Frame

Frame Accessories

Fiber Optic Terminal Jumper Storage Panel

Ordering Information

Description	Dimensions (HxWxD)	Catalog Number
Frame zoning: by vertical, 305 mm (12") F MDF	2.14 m x 305 mm x 610 mm (7' x 12" x 24")	NGF-ACCFOTSB
Front facing F3MDF	2.14 m x 305 mm x 483 mm (7' x 12" x 19")	NGF-F3ACCFOTSB
Frame zoning: by frame, 203 mm (8") F MDF left vertical	2.14 m x 203 mm x 610 mm (7' x 8" x 24")	NGF-ACCFOTSB-SL
F MDF right vertical	2.14 m x 203 mm x 610 mm (7' x 8" x 24")	NGF-ACCFOTSB-SR
Front facing F3MDF left vertical	2.14 m x 203 mm x 483 mm (7' x 8" x 19")	NGF-F3ACCFOTSB-SL
Front facing F3MDF right vertical	2.14 m x 203 mm x 483 mm (7' x 8" x 19")	NGF-F3ACCFOTSB-SR



NGF Optical Distribution Frame

Frame Accessories

Equipment Frame

The NGF equipment frame provides a mounting location for 19- or 23-inch rack mount equipment within FMDF lineups. The equipment deployed in the frame can include video transmitters, RF splitter/combiners or remote fiber test systems. NGF equipment frames are available for FMDF lineups 24-inches deep and F3MDF lineups 19-inches deep. Each frame section includes heavy duty floor anchor bolts for concrete floor applications.

As applications and requirements for equipment frames in the NGF lineups vary greatly from office to office, ordering information for equipment frames can be obtained by contacting the ADC Technical Assistance Center.



Equipment Frame



Next Generation Frames

Frame Accessories

Equipment Frame Splicing Solutions

For additional splice panel options, please call the ADC Technical Assistance Center, 1-800-366-3891.

Ordering Information

Description	Dimensions (HxWxD)	Catalog Number
Splicing solution in equipment frame Splice panel accommodates 216 splices	229 mm x 584 mm x 254 mm (9" x 23" x 10")	NGF-SPLC21600
Cable clamp bracket (holds 6 clamps)		NGF-ACCSPLC01
Cable clamp		F3C-ACC001

Splice Trays

Ordering Information

Description	Number of Splices per Tray	Number of Splice Trays per Drawer	Splice Module Capacity	Catalog Number
12-position splice trays single height				
Bare fusion	12	2	192	FST-FT
Heat shrink (single fiber fusion)	12	2	192	FST-HS
Mechanical (mass fusion) ²	12	2	192	FST-MT
Nortel QPAK	12	2	192	FST-NT
18-position splice trays single height				
Heat shrink (single fiber fusion) with (3) 6-position chips	18 ¹	2	192	FST-HS-3
24-position splice trays dual height				
Bare fusion	24	1	192	FST-D-FT
Heat shrink (single fiber fusion)	24	1	192	FST-D-HS
Mechanical (mass fusion) ²	24	1	192	FST-D-MT
Nortel QPAK	24	1	192	FST-D-NT

¹ Used with 8 fiber soft-wall bundled pigtail assembly, maximum 24 fibers per drawer

² May be used with mass fusion type splice protector sleeves. See information on protector sleeve ordering information, page 20.



NGF Optical Distribution Frame

Frame Accessories

NGF to NG3® Frame Spacer Kit

The 2.5-inch wide frame spacer kit is required for transition between next generation frames (NGFs) and NG3 frames. The kit includes six rear trough adapters that ensure the rear cable management features of both fiber frames are utilized. Tie brackets and a kick plate are also included for a secure installation. For technical documents outlining the proper procedure for making these transitions, please contact your ADC sales representative.

Ordering Information

Description	Catalog Number
Mounts on left side of NGF frame and right side of NG3 frame	NG3-NGFTRNTWN7A0R
Mounts on right side of NGF frame and left side of NG3 frame	NG3-NGFTRNTWN7A0L

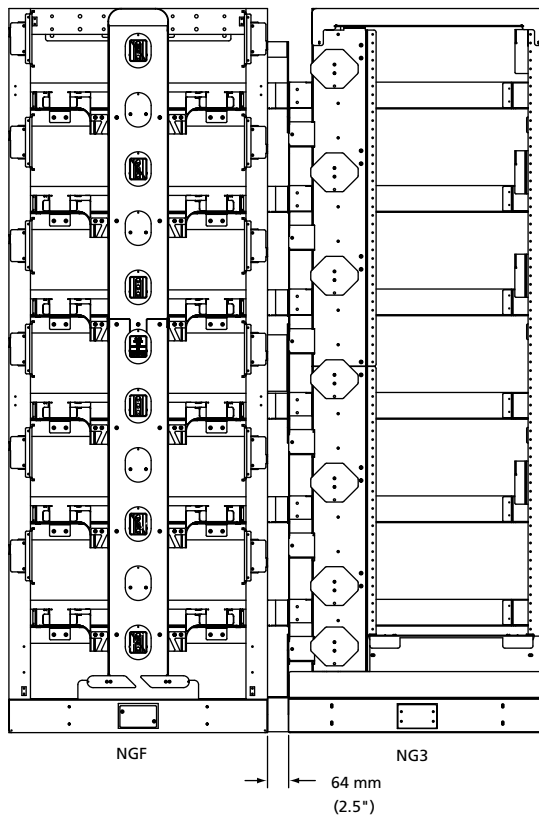

Frame Spacer Kit
(NG3-NGFTRNTWN7A0L Shown)



NGF Optical Distribution Frame

Frame Accessories

End Guard

End guards provide protection for the fibers entering and exiting frames at the end of a lineup. They are designed for universal fit to be used on either end of the lineup.

Ordering Information

Description	Dimensions (HxWxD)	Catalog Number
FMDF end guard	2.14 m x 127 mm x 610 mm (7' x 5" x 24")	NGF-ACCEGD007
Front facing F3MDF end guard	2.14 m x 127 mm x 483 mm (7' x 5" x 19")	NGF-F3ACCEGD007

Work Shelf

The work shelf can mount at any one of six positions within the 30-inch NGF frame and anywhere along the height of the frame. It provides a surface for miscellaneous objects (i.e. isopropyl alcohol, tissues and cotton swabs for cleaning connectors); also provides a writing surface; or serves as an aid in field terminating cables and jumpers.

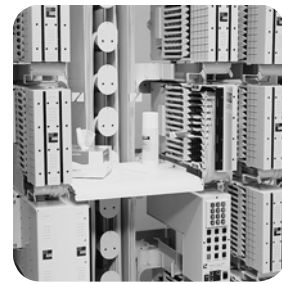

Ordering Information

Description	Catalog Number
Work shelf; 762 mm (30")	NGF-ACCSHELF1-30



NGF Optical Distribution Frame

Frame Accessories

Frame Extender

Frame extenders are used to extend the height of a 7-foot frame to the appropriate ceiling height so that it can be secured overhead.

Ordering Information

Description	Catalog Number	
	762 mm (30") Wide Frames	Slim Rack
305 mm (12")	NGF-ACCEXT12-30	NGF-ACCEXTSLM12
610 mm (24")	NGF-ACCEXT24-30	NGF-ACCEXT24-SR
1.4 m (54")	NGF-ACCEXT54-30	NGF-ACCEXT54-SR

Grounding Kit

The fiber distribution frame is equipped with a grounding kit designed with mechanical fittings including clamps, straps and connectors. Order this kit only if you are building a frame using your own frame. When connecting frame ground to office ground conductor, an H-TAP bonding kit should also be ordered.

Grounding kit includes:

2 hole terminal lug	1 each
#6 AWG copper tinned wire	13'
Wire clips	8 each
#12-24 x 1/2" screws	10 each

H-TAP bonding kit includes:

H-TAP	1 each
H-TAP insulated cover	1 each
2 hole terminal lug, crimp	3 each
Terminal lug, screw	4 each
#6 AWG stranded insulated wire	2'
Star washer	6 each
No-ox grease	1 tube

Ordering Information

Description	Catalog Number
Grounding kit	E-501-L37*
H-TAP bonding kit	E-501-L166

*Included with all NGF frames

AC Outlet Kit

The AC outlet kit provides the hardware for mounting AC power outlets on the frame. Each kit includes a prewired AC power outlet strip that mounts at the bottom of the frame.

Ordering Information

Description	Catalog Number
Dual outlet; mounts in base of NGF	ACOK-2
AC outlet cover kit	RAC-0X0493



NGF Optical Distribution Frame

Frame Accessories

Frame Installation Kit

Frame installation kits may be used on network frames and are seismic zone 4 rated.

Computer floor kit includes:

Threaded rods	4 each, 5/8" – 11" x 30"
Heavy nuts, locks and flat washers	12 each
Nuts with springs	4 each, 1/2" x 30" and shoulder washers
Unistrut and anchor kit	1 each, 10'

Overhead support kit includes:

Designation card holder	1 each
Two-bar channel	4 each
Framing clip with 0.56	4 each
Framing clip with 0.69	4 each
Clip J-bolt	4 each, 1/2" – 13" x 18" long
Threaded rod	2 each, 5/8" x 18" long
Hex nut	4 each, 1/2" x 13"
Hex nut	4 each, 5/8" x 11"

Ordering Information

Description	Catalog Number
Frame installation kit for Computer floor	DFD-ACC146
Overhead support	RINST-TOP7

Isolation Pad

A template for frame installation providing isolation between the frame and the ground.

Ordering Information

Description	Catalog Number
Isolation pad for NGF FMDf and equipment frames	NGF-ACCISOP30X24
NGF front facing F3MDF and equipment frames	NGF-ACCISOP30X19
NGF slim racks	NGF-ACCISOP19X19
NGF-ACCFOTSB storage panels	NGF-ACCISOPFS12X24
NGF-F3ACCFOTSB storage panels	NGF-ACCISOPFS12X19
End guards for 610 mm (24") deep FMDf frames	NGF-ACCISOPEG24
End guards for 483 mm (19") deep F3MDF frames	NGF-ACCISOPEG19



NGF Optical Distribution Frame

Panel Accessories

Cable Clamp Kit

Cable clamp kits are available for securing IFC/OSP cable or equipment (FOT) jumpers on the rear of the FTB. Each FTB has three cable clamp mounting positions.

Cable clamp kit for FOT patch cord includes:

Cable clamp bracket	1 each
O-ring	1 each
Screws	2 each

Cable clamp kit for IFC/OSP cables includes:

Clamp cover	1 each
Clamps	2 each
0.5" Grommet (inner diameter)	1 each
0.6" Grommet (inner diameter)	1 each
0.7" Grommet (inner diameter)	1 each
#14 - #6 AWG split bolt	1 each
Shield bonding connector	1 each
1-foot lead wire	1 each
#6 AWG ring terminal lug	1 each
Clamp cover plate	1 each

Ordering Information

Description	Catalog Number
Cable clamp kit for FOT patch cords (included with fiber termination blocks loaded with adapters only)	NGF-ACCCLMP04
Cable clamp kit* for IFC/OSP cables, dielectric cable without grounding hardware (included with fiber termination blocks with IFC)	NGF-ACCCLMP08

* One NGF-ACCCLMP08 is also included with each cable clamp kit and block conversion kit (see page 17).



NGF Optical Distribution Frame

Panel Accessories

Sliding Adapter Pack

Sliding adapter packs house groups of fiber optic adapters and are mounted in fiber termination blocks to provide easy access to connectors. Sliding adapter packs are available with SC, FC and LC adapters. The adapters come in packs of two, four, six and eight depending on the adapter type and the desired termination density. See table below for configuration guidelines.



Type A
(SC shown)



Type K
(SC shown)



Type K
(LC shown)

Sliding Adapter Pack Configuration Guidelines

Block Capacity	Adapter Type	Adapter Pack Configuration	Adapter Pack Type
72-position	SC	2 pack / 4 pack	A (shown above)
72-position	FC	6 pack	E
96-position	SC, FC	4 pack / 4 pack	J
144-position (block code 'M')	SC, FC, LC	6 pack / 6 pack	K (shown above)
192-position (block code 'Q')	LC	8 pack / 8 pack	J

Catalog Number

NGF-SAP _ 0 _ 00

Adapter Type

Singlemode	
7	SC ultra polish
L	SC angled polish
2	FC ultra polish
K	LC ultra polish (192 and 144 only)
M	LC angled polish (192 and 144 only)
Multimode	
9	SC
P	LC

Adapter Pack Type

A	2 pack / 4 pack
E	6 pack
J	4 pack / 4 pack ¹
K	6 pack / 6 pack (all block code "M" blocks)

¹ 8 pack / 8 pack with LC configuration.

Other configurations are available upon request. Please contact ADC Technical Assistance Center.



NGF Optical Distribution Frame

Frame Accessories

Standard Cross-Connect Patch Cord Lengths

Total Number of Sections Traversed*	Approximate Patch Cord Length Meters (Feet)
Same frame	6 m (18')
Adjacent frames	7 m (23')
3 to 4	8 m (26')
5 to 6	10 m (33')
7 to 8	11 m (36')
9 to 10	12 m (39')

*Depending on office requirements, 11 or more frame sections may require the use of interbay tie panels. For additional information, please call ADC Technical Assistance Center, 1-800-366-3891. For recommended cross-connect method and installation instructions, refer to User Manual ADCP-90-285.

Ordering Information for Patch Cords and Attenuators

ADC offers a comprehensive line of cable assembly and accessory products including patch cords, IFC assemblies, attenuators, FasTerm® connectors and adapters to meet the demanding needs of today's network. Please refer to the **Fiber Cable Assemblies Catalog #102880AE** at www.adc.com for more detailed information. For your convenience, ordering information for patch cords and attenuators can also be found on pages 122–127.